

2 BAR LIFT MECHANISM

Use at own risk. Pandemic Haunt Production LLC does not assume any responsibility for misuse, damages, injury or death from this design. Pneumatics, although relatively safe, can be dangerous if not used with caution. This mechanism is not designed for air pressure above 125 psi. This mechanism is not designed for commercial use. These plans are not to be copied, duplicated or distributed without approval from Pandemic Haunt Production LLC.

If there are any questions, please feel free to e-mail us at Dave@PandemicHauntProduction.com

www.PandemicHauntProduction.com

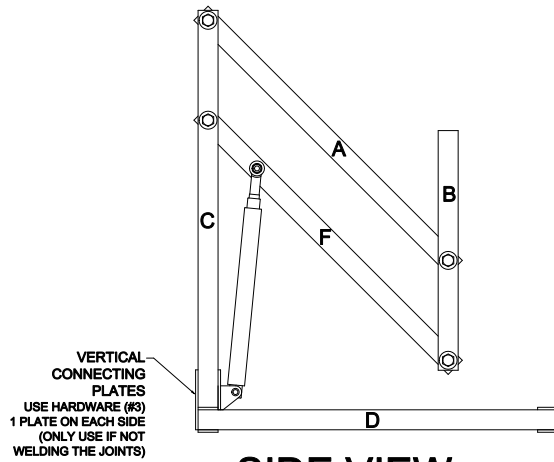

**SIDE VIEW
RETRACTED**

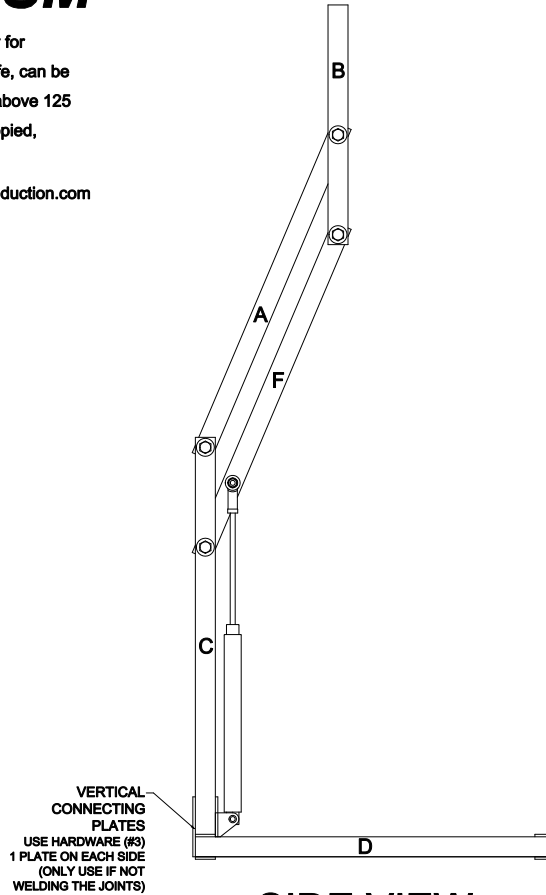

**SIDE VIEW
EXTENDED**

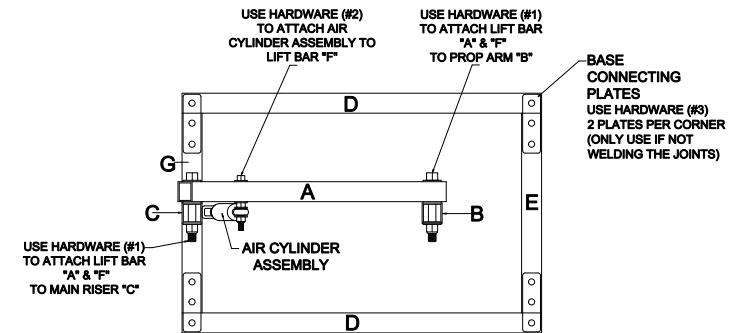

TOP VIEW

A

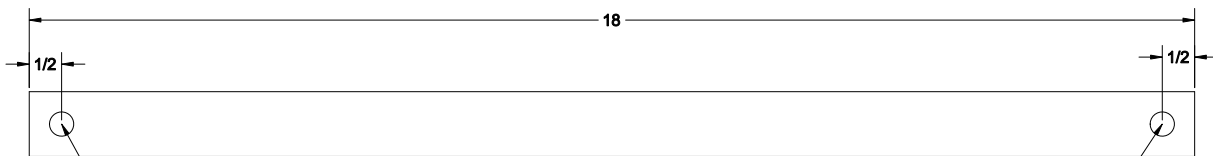

DRILL 3/8 DIA HOLE
THRU CENTER-LINE
OF TUBE.

DRILL 3/8 DIA HOLE
THRU CENTER-LINE
OF TUBE.

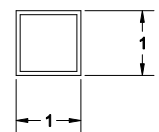

**MATERIAL : 1in X 1in X 1/16 wall thickness SQUARE TUBE
MILD STEEL**

ZONE		REV	DESCRIPTION	DATE	APPROVED
REVISIONS					

<p>THIS DRAWING CONTAINS CONFIDENTIAL INFORMATION AND IS ISSUED IN CONFIDENCE THAT IT NOT BE COPIED, REPRODUCED, DISCLOSED TO OTHERS OR USED IN MANUFACTURE OF THE SUBJECT MATTER THEREOF WITHOUT WRITTEN CONSENT OF PANDEMIC HAUNT PRODUCTION</p>		Pandemic Haunt Production LLC			
		Lift Bar "A"			
SIZE	FSCM NO.	DWG NO.	REV		
			1		
SCALE			SHEET		

B

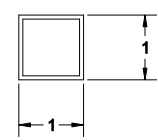
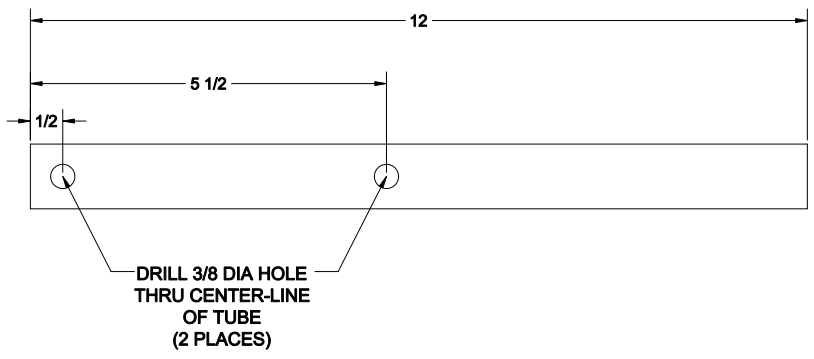

**MATERIAL : 1in X 1in X 1/16 wall thickness SQUARE TUBE
MILD STEEL**

THIS DRAWING CONTAINS CONFIDENTIAL INFORMATION AND IS ISSUED IN CONFIDENCE THAT IT NOT BE COPIED, REPRODUCED, DISCLOSED TO OTHERS OR USED IN MANUFACTURE OF THE SUBJECT MATTER THEREOF WITHOUT WRITTEN CONSENT OF PANDEMIC HAUNT PRODUCTION	Pandemic Haunt Production LLC		
	PROP BAR "B"		
SIZE	FSCM NO.	DWG NO.	REV
			1
SCALE		SHEET	

C

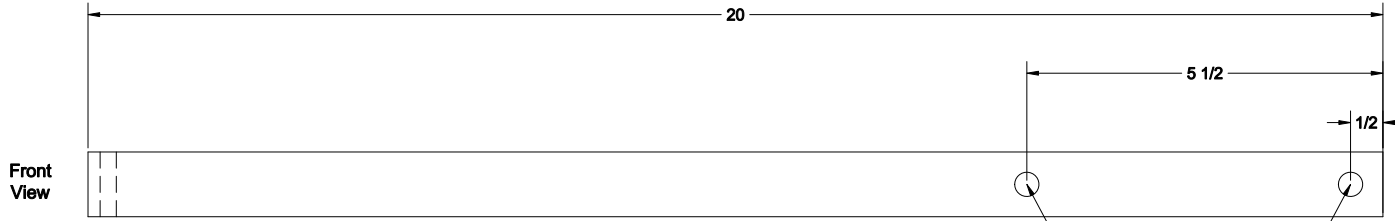

Front View

DRILL 3/8 DIA HOLE THRU CENTER-LINE OF TUBE. (2 PLACES)

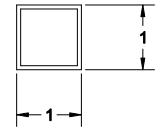

Side View

DRILL 1/4 HOLE THRU CENTER-LINE OF TUBE (1 PLACE)

MATERIAL : 1in X 1in X 1/16 wall thickness SQUARE TUBE MILD STEEL

ZONE		REV	DESCRIPTION	DATE	APPROVED

<p>THIS DRAWING CONTAINS CONFIDENTIAL INFORMATION AND IS ISSUED IN CONFIDENCE THAT IT NOT BE COPIED, REPRODUCED, DISCLOSED TO OTHERS OR USED IN MANUFACTURE OF THE SUBJECT MATTER THEREOF WITHOUT WRITTEN CONSENT OF PANDEMIC HAUNT PRODUCTION</p>		<p>Pandemic Haunt Production LLC</p>	
<p>SIZE</p>		<p>FSCM NO.</p>	
<p>SCALE</p>		<p>DWG NO.</p>	
<p>SHEET</p>		<p>REV 1</p>	

8 7 6 5 4 3 2 1

REVISIONS				
ZONE	REV	DESCRIPTION	DATE	APPROVED

D

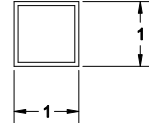
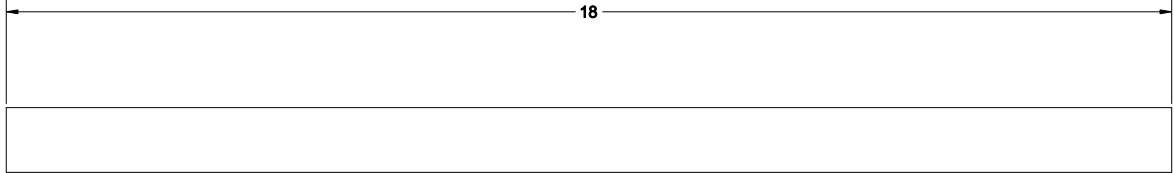

D

D

C

C

B

B

A

A

MATERIAL : 1in X 1in X 1/16 wall thickness SQUARE TUBE
MILD STEEL

<p>THIS DRAWING CONTAINS CONFIDENTIAL INFORMATION AND IS ISSUED IN CONFIDENCE THAT IT NOT BE COPIED, REPRODUCED, DISCLOSED TO OTHERS OR USED IN MANUFACTURE OF THE SUBJECT MATTER THEREOF WITHOUT WRITTEN CONSENT OF PANDEMIC HAUNT PRODUCTION</p>	<p>Pandemic Haunt Production LLC</p>		
	<p>LONG BASE LEG "D"</p>		
<p>SIZE</p>	<p>FSCM NO.</p>	<p>DWG NO.</p>	<p>REV 1</p>
<p>SCALE</p>	<p>SHEET</p>		<p>1</p>

8 7 6 5 4 3 2 1

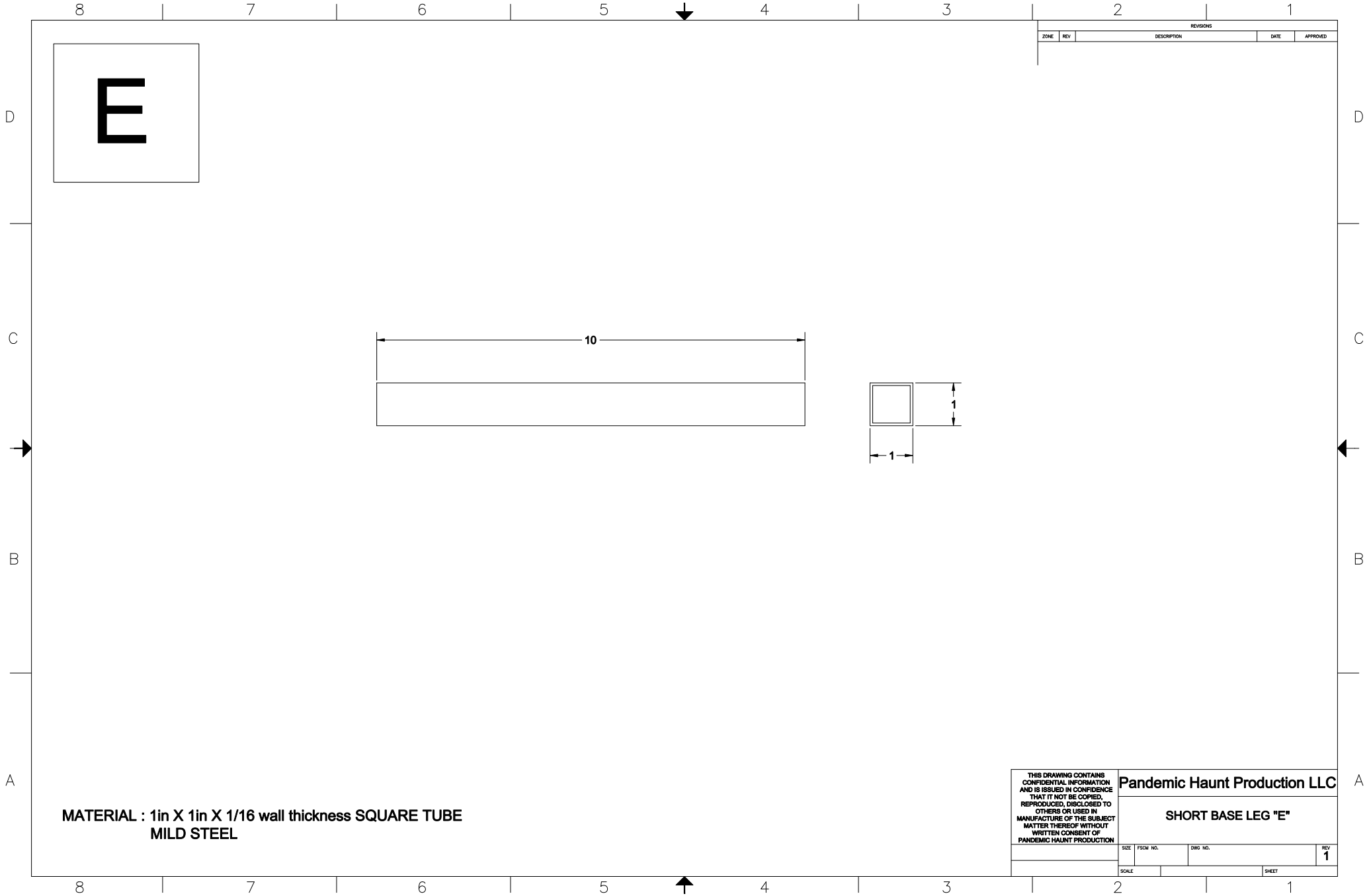

**MATERIAL : 1in X 1in X 1/16 wall thickness SQUARE TUBE
MILD STEEL**

THIS DRAWING CONTAINS CONFIDENTIAL INFORMATION AND IS ISSUED IN CONFIDENCE THAT IT NOT BE COPIED, REPRODUCED, DISCLOSED TO OTHERS OR USED IN MANUFACTURE OF THE SUBJECT MATTER THEREOF WITHOUT WRITTEN CONSENT OF PANDEMIC HAUNT PRODUCTION		Pandemic Haunt Production LLC	
		SHORT BASE LEG "E"	
SIZE	FSCM NO.	DWG NO.	REV
			1
SCALE		SHEET	

REVISIONS				
ZONE	REV	DESCRIPTION	DATE	APPROVED

F

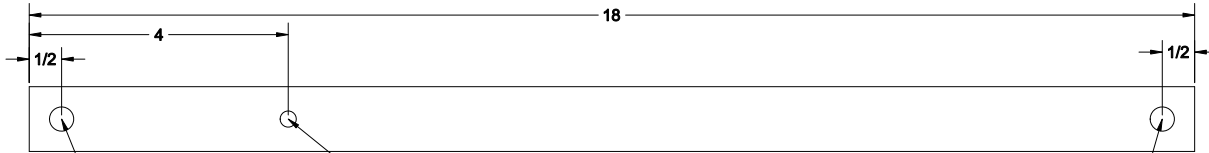

DRILL 3/8 DIA HOLE
THRU CENTER-LINE
OF TUBE
(2 PLACES)

DRILL 1/4 DIA HOLE
THRU CENTER-LINE
OF TUBE
(1 PLACE)

DRILL 3/8 DIA HOLE
THRU CENTER-LINE
OF TUBE
(2 PLACES)

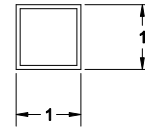

**MATERIAL : 1in X 1in X 1/16 wall thickness SQUARE TUBE
MILD STEEL**

ZONE		REV	DESCRIPTION	DATE	APPROVED

<p>THIS DRAWING CONTAINS CONFIDENTIAL INFORMATION AND IS ISSUED IN CONFIDENCE THAT IT NOT BE COPIED, REPRODUCED, DISCLOSED TO OTHERS OR USED IN MANUFACTURE OF THE SUBJECT MATTER THEREOF WITHOUT WRITTEN CONSENT OF PANDEMIC HAUNT PRODUCTION</p>		<p>Pandemic Haunt Production LLC</p>	
<p>Lift Bar "F"</p>		<p>SIZE: FSCM NO.: DWG NO.: REV: 1</p>	
<p>SCALE:</p>		<p>SHEET:</p>	

G

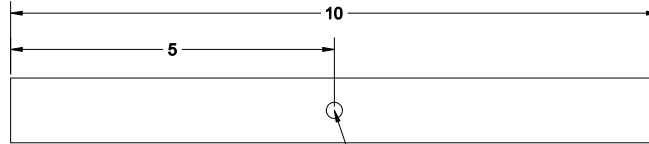

DRILL 1/4 HOLE
THRU CENTER-LINE
OF TUBE

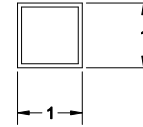

**MATERIAL : 1in X 1in X 1/16 wall thickness SQUARE TUBE
MILD STEEL**

REVISIONS				
ZONE	REV	DESCRIPTION	DATE	APPROVED

<small>THIS DRAWING CONTAINS CONFIDENTIAL INFORMATION AND IS ISSUED IN CONFIDENCE THAT IT NOT BE COPIED, REPRODUCED, DISCLOSED TO OTHERS OR USED IN MANUFACTURE OF THE SUBJECT MATTER THEREOF WITHOUT WRITTEN CONSENT OF PANDEMIC HAUNT PRODUCTION</small>	Pandemic Haunt Production LLC			
	SHORT BASE LEG "G"			
SIZE	FSCM NO.	DWG NO.	REV	1
SCALE	SHEET			1

AIR CYLINDER ASSEMBLY

Note: With this assembly, the mechanism can lift about a 7lb prop. If you need to lift more weight, use a 1 1/16 bore cylinder with matching 5/16-24 spherical rod end.

SPHERICAL ROD END

1/4-28 THREAD
SKU# 0582-0022
(FRIGHTPROPS.COM)

CYLINDER

3/4 BORE
6" STROKE
DOUBLE ACTING
UNIVERSAL MOUNT
SKU # 0758-0750-6
(FRIGHTPROPS.COM)

USE HARDWARE (#3)

TO ATTACH FOOT BRACKET
TO MAIN RISER "C"
YOU WILL HAVE TO GRIND
THE SIDES DOWN ON THE HEAD
OF THE CARRIAGE BOLTS SO
THEY WILL FIT INSIDE THE BRACKET.
(SEE DESCRIPTION BELOW)

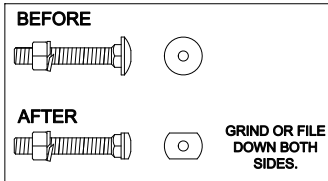

PIVOT BRACKET

ONE PIECE WITH PIN
1/4 Hole with 3/8 Opening
SKU # 0776-0380
(FRIGHTPROPS.COM)

REVISIONS				
ZONE	REV	DESCRIPTION	DATE	APPROVED

THIS DRAWING CONTAINS CONFIDENTIAL INFORMATION AND IS ISSUED IN CONFIDENCE THAT IT NOT BE COPIED, REPRODUCED, DISCLOSED TO OTHERS OR USED IN MANUFACTURE OF THE SUBJECT MATTER THEREOF WITHOUT WRITTEN CONSENT OF PANDEMIC HAUNT PRODUCTION		Pandemic Haunt Production LLC		
AIR CYLINDER ASSEMBLY		SIZE	FSCM NO.	DWG NO.
SCALE		SHEET		REV 1

8 7 6 5 4 3 2 1

ZONE		REV	DESCRIPTION	DATE	APPROVED

HARDWARE (#1)

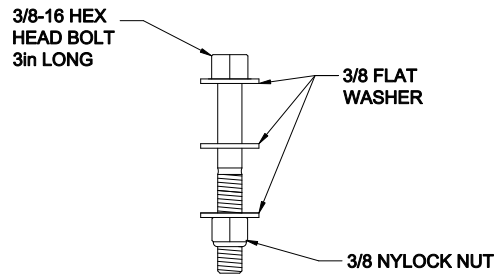

HARDWARE (#2)

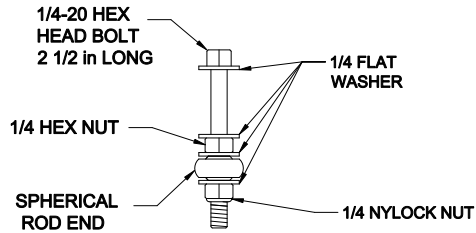

HARDWARE (#3)

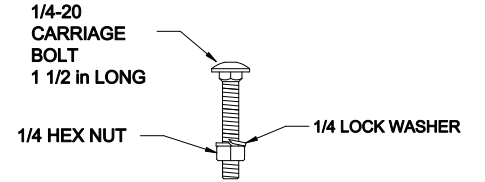

<p>THIS DRAWING CONTAINS CONFIDENTIAL INFORMATION AND IS ISSUED IN CONFIDENCE THAT IT NOT BE COPIED, REPRODUCED, DISCLOSED TO OTHERS OR USED IN MANUFACTURE OF THE SUBJECT MATTER THEREOF WITHOUT WRITTEN CONSENT OF PANDEMIC HAUNT PRODUCTION</p>	<p>Pandemic Haunt Production LLC</p>			
	<p>HARDWARE</p>			
SIZE	FSCM NO.	DWG NO.	REV	1
SCALE		SHEET		

8 7 6 5 4 3 2 1

VERTICAL CONNECTING PLATES

NEED 2 pcs
(ONLY USE IF NOT WELDING
THE JOINTS)

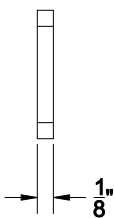
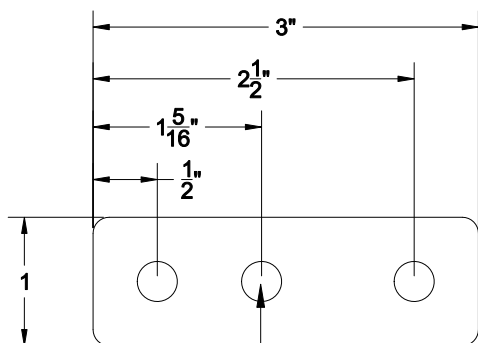

DRILL 5/16 DIA HOLES
THRU PLATE
(3 PLACES)

MATERIAL : 1in X 1/8 FLAT STOCK
MILD STEEL

BASE CONNECTING PLATES

NEED 8 pcs
(ONLY USE IF NOT WELDING
THE JOINTS)

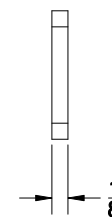
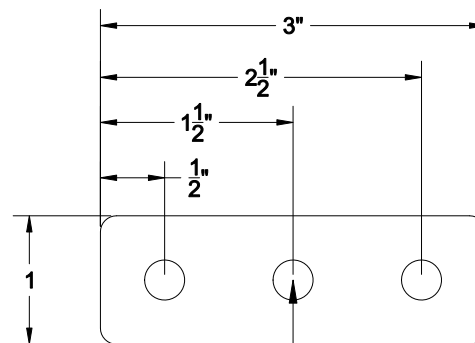

DRILL 5/16 DIA HOLES
THRU PLATE
(3 PLACES)

THIS DRAWING CONTAINS CONFIDENTIAL INFORMATION AND IS ISSUED IN CONFIDENCE THAT IT NOT BE COPIED, REPRODUCED, DISCLOSED TO OTHERS OR USED IN MANUFACTURE OF THE SUBJECT MATTER THEREOF WITHOUT WRITTEN CONSENT OF PANDEMIC HAUNT PRODUCTION	Pandemic Haunt Production LLC		
	VERTICAL CONNECTING PLATES		
SIZE	PSCM NO.	DWG NO.	REV 1
SCALE			SHEET